



TECHedition



24.01.2005

Topic : PMC & MC 25
TEC edition No : TEC/E/005/2015
Date issued : 10th June, 2015
DESCRIPTION : Modify the Limit Switch

PREVIOUSLY

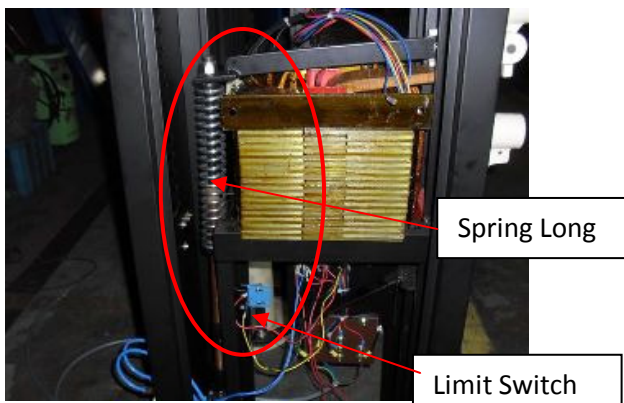

NEW CHANGES

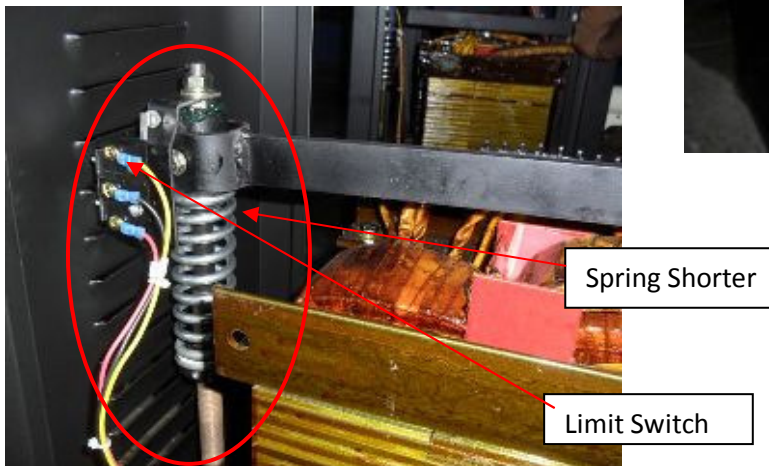

Effected Model

PMC25 & MC 25

Effective date

Machine will effective by serial number as below:-

- MC25 start by serial number 01303, 01316

Remark

Improvement –

This will prevent readjustment in the Limit Switch if adjust the Tip Holder



Contact:

Mr. Kong Siew Wai – Customer Service Department
Phone : ++ (60)5-365-6353 / Fax: ++ (60)5-366-8328
E-mail : customer@wim.com.my

www.wim.com.my